

OUR PRODUCTS



POURING
PERFECTION

How we work...

We make our decisions, and particularly the difficult ones, based on four core beliefs:

<p>1</p> <p>Reacting to the market and our customer's evolving desires, we try always to meet all requests faster than customer expectations.</p> <p>dynamism</p>	<p>2</p> <p>Customers, Employees, the Environment and society; all deserve respect. We believe that.</p> <p>care</p>	<p>3</p> <p>It is best to be clear, direct and transparent in all dealings. It makes things simpler for all.</p> <p>honesty</p>	<p>4</p> <p>Quality in the cup, engineering excellence and precise water management are possible through a deep knowledge of what these things mean. An ongoing project.</p> <p>knowledge</p>
--	---	--	--

We believe in design. To design is to create and to innovate, which we love to do. We attempt to split our design output into three distinct sections

<p>1</p> <p>This is the core of our output – marrying technological and brewing excellence within the Marco range of products, always looking to the next generation</p> <p>strategic design</p>	<p>2</p> <p>We love to work directly with our customers to deliver specific machines for specific solutions. Unique solutions for unique needs.</p> <p>customer OEM solutions</p>	<p>3</p> <p>Through the Marco Über Project, we encourage our designers and engineers to experiment and question, play and learn. From this comes the future.</p> <p>playtime</p>	
---	--	---	--

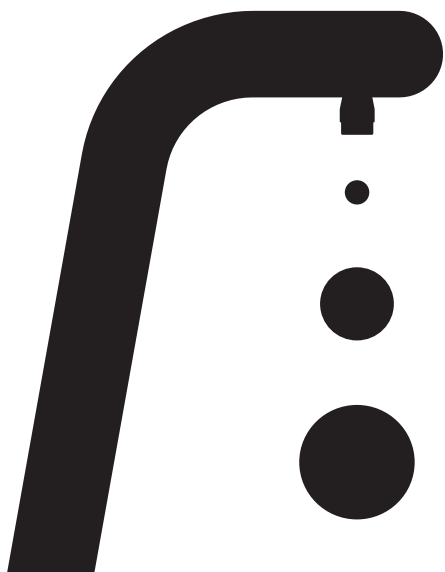

A vehicle for promoting new ideas, almost a design company within a company, the Über Project develops linkages within the industry community to stretch and challenge our understanding of future possibilities and to fulfil as yet unknown needs and desires... a continuous work in progress.

Über project

www.marco Beveragesystems.com/uberproject

www.twitter.com/MarcoBevSystems

www.facebook.com/MarcoBeverageSystems

www.linkedin.com/company/marco-beverage-systems

Contents



Water Boilers

Ecoboiler Tap	1
Ecoboiler Push Button	2
Ecosmart	3
Ecoboiler Wall Mount	4
Ecoboiler Undercounter	5
Über Boiler	6
Pressure Boilers	7
Manual Fill	8

Coffee Brewers

BRU	10
Shuttle Brewers	11
Qwikbrew	12
Qwikbrew Twin / Maxibrew Twin	13
Self Service Bulk Brew	14

Other

Grinders	9
Water Filter Systems	15
>	
Machine Selection Chart	16
Customer Care / Spares & Service	17

www.marcobeveragesystems.com



Ecoboiler Tap

Tap dispense
atmospheric water boilers

Features

- Best in class energy efficiency
- 4 models with 5L to 30L capacity
- Compact footprint
- Plumbed into mains supply
- Excellent value for money
- Easy to descale and service
- Electronic control
- Made with 95% recyclable material



T10



T20



T5

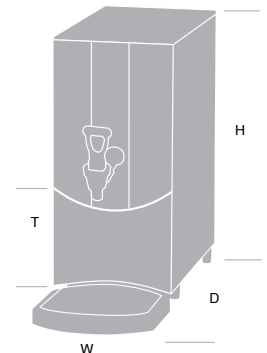

Options

Ideal for all catering locations –
hotel and restaurant kitchens, coffee shops, canteens.

Ecoboiler Tap	Order Code	Immediate Draw Off	Output Per Hour	Cups Per Hour	Dimensions (DxWxHmm)	T(mm)	Power @ 230V	Weight (kg)	Packing (mm) Dimensions	Qty Pallet	Plumbing Requirements
Ecoboiler T5	1000660	5.0L	28.0L	156	505x210x465	185	2.8kW	10	550x560x290	18	3/4" BSP
Ecoboiler T10	1000661	10.0L	28.0L	156	505x210x590	185	2.8kW	12.5	290x690x560	18	3/4" BSP
Ecoboiler T20	1000662	20.0L	28.0L	156	566x240x690	185	2.8kW	19	600x350x840	10	3/4" BSP
Ecoboiler T30	1000663	30.0L	56.0L	311	570x300x690	185	5.6kW	22	600x380x840	10	3/4" BSP



Push-button dispense
atmospheric water boilers

Features

- Best in class energy efficiency
- 5 & 10L options, others on request
- Compact footprint
- Plumbed into mains supply
- Excellent value for money
- Easy to descale and service
- Electronic control
- Made with over 95% recyclable materials
- Takes up to 40cl (14oz) cup – 'to go drinks'

Options

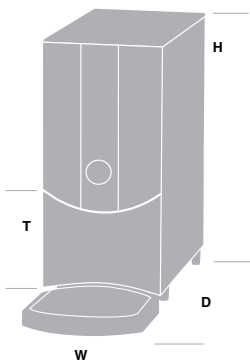

PB5



PB10

Ideal for all self-service locations –
grab and go applications, canteens, coffee shops, restaurants, offices, small sites.

Ecoboiler Push Button	Order Code	Immediate Draw Off	Output Per Hour	Cups Per Hour	Dimensions (DxWxHmm)	T(mm)	Power @ 230V	Weight (kg)	Packing (mm) Dimensions	Qty Pallet	Plumbing Requirements
Ecoboiler PB5	1000665	5.0L	28.0L	156	464x210x465	130	2.8kW	10	560x460x290	18	3/4" BSP
Ecoboiler PB10	1000666	10.0L	28.0L	156	464x210x590	130	2.8kW	12.5	560x740x550	18	3/4" BSP



Ecosmart

Programmable push-button
dispense atmospheric water boilers

Features

- Ecoboiler performance
- Programmable portion dispense
- Variable height options
- Operator adjustable temperature
- Programmable pulse feature
- Electronic control
- Easy to read LCD Panel
- Live temperature readout
- Filter change flag



PB10



PB10 Hi Deck

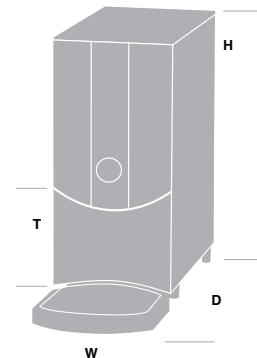

Options

Ideal for catering or self-service applications with variable, transparent temperatures and user control.

Ecosmart	Order Code	Immediate Draw Off	Output Per Hour	Cups Per Hour	Dimensions (DxWxHmm)	T(mm)	Power @ 230V	Weight (kg)	Packing (mm) Dimensions	Qty Pallet	Plumbing Requirements
Ecosmart PB10	1000677	10.0L	28.0L	156	464x210x590	130	2.8kW	14.5	310x470x840	14	3/4" BSP
Ecosmart PB10 Hi Deck	1000678	10.0L	28.0L	156	464x210x675	215	2.8kW	14.5	310x470x840	14	3/4" BSP

Tap or push-button dispense
wall-mounted atmospheric water boilers

Features

Slim wall-mount hot water dispense
Tap or push-button dispense
Best in class energy efficiency
5L immediate draw off
Plumbed into mains water supply
Excellent value for money
Easy to descale and service
Electronic control and diagnostics
Precise water temperature control

Options

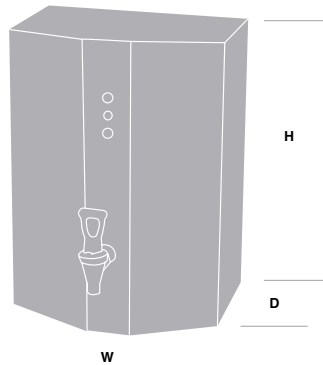

WMT5

Ideal for hospital and nursing home wards,
office canteens, small sites.

Ecoboiler Wall-Mount	Order Code	Immediate Draw Off	Output Per Hour	Cups Per Hour	Dimensions (DxWxHmm)	Power @ 230V	Weight (kg)	Packing (mm) Dimensions	Qty Pallet	Plumbing Requirements
Ecoboiler WMT5	1000671	5.0L	24.0L	133	222x325x447	2.4kW	12	330x410x480	16	3/4" BSP

Ecoboiler Under-counter

Ecoboiler & Ecosmart undercounter units

Features

- Undercounter water management system for space saving applications
- Versatile, modular framework
- Available with Ecoboiler or Ecosmart options
- 4L-75L volume options
- Single or dual dispense fonts
- Up to 3 fonts from a single boiler (45L-75L models)
- Portion dispense option



Options



Ecosmart UC10

Ecosmart UC4

Ecoboiler UC45

Über font 2 palm button

Ideal for all catering locations – hotel and restaurant kitchens, coffee shops, staff restaurants, stadia, canteens.

Ecoboiler Undercounter	Order Code	Immediate Draw Off	Output Per Hour	Cups Per Hour	Dimensions (DxWxHmm)	Power @ 230V	Weight (kg)	Packing (mm) Dimensions	Qty Pallet	Plumbing Requirements
Ecoboiler UC4	1000740	4.0L	24.0L	133	394x135x585	2.4kW	11	400x150x570	10	3/4" BSP
Ecoboiler UC10	1000741	10.0L	28.0L	156	394x226x585	2.8kW	12.5	400x230x570	10	3/4" BSP
Ecoboiler UC45	1000744	45.0L	56.0L	311	495x420x650	5.6kW	22	500x420x690	4	3/4" BSP
Ecoboiler UC75	1000179	75.0L	84.0L	462	575x557x660	8.4kW 3ph	30	1200x800x1000	2	3/4" BSP
Ecosmart UC4	1000750	4.0L	24.0L	133	394x135x585	2.4kW	11	400x150x570	10	3/4" BSP
Ecosmart UC10	1000751	10.0L	28.0L	156	394x226x585	2.8kW	12.5	400x230x570	10	3/4" BSP
Ecosmart UC45	1000754	45.0L	56.0L	311	495x420x650	5.6kW	22	500x420x690	4	3/4" BSP

Fonts

Tubular Font 1000585 : Dimensions (mm) T135x D156x W123x H300

Über Font 2 Palm Button 1000821 **Über Font 2 Slim Button Head** 1000816 **Über Font 2 Slim Button Tile** 1000811 : Dimensions (mm) T270x D470x W250x H400

Über Boiler

Precision brewing station for brew-by-brew excellence

Features

- Incorporates water drain, weighing scales, timer and high precision temperature delivery
- 0.1°C accurate with patented APLogic™ software
- Variable manual control flow rate
- Joystick for directional flow
- For high precision applications

Options

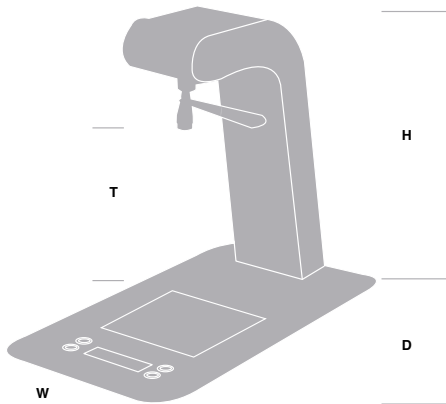

Über Boiler

Ideal for high precision manual brewing of speciality coffee and tea.

Über Boiler	Order Code	Immediate Draw Off	Output Per Hour	Cups Per Hour	Dimensions (mm) Over Counter	Dimensions (mm) Under Counter	T(mm)	Power @ 230V	Weight (kg)	Packing (mm) Dimensions	Qty Pallet	Plumbing Requirements
Über Boiler	1000680	6L	28.0L	156	*470x250x400	*405x190x400	270	2.8kW	24	570x340x1000	5	3/4" BSP

*(DxWxHmm)

Pressure Boilers

Pressure boilers

Features

- Compact design with high volume output
- Hot water and steam delivery
- Stainless steel finish
- Electronic controls
- Counter top and under counter versions
- Under counter fonts supplied as standard
- Capacity range 11L-72L
- Choice of power options available



Major 900 counter top

Options



Font

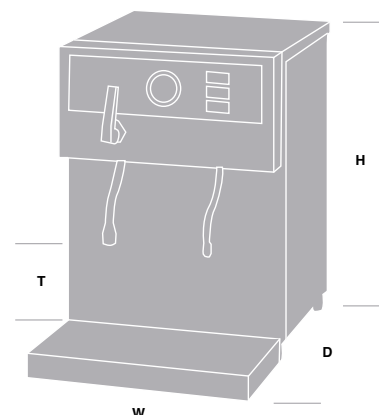

Ideal for high volume locations, fast & efficient, e.g. kitchens, tea specialists and motorway service stations.

Pressure Boilers	Order Code	Immediate Draw Off	Output Per Hour	Cups Per Hour	Dimensions (DxWxHmm)	T(mm)	Power @ 230V	Weight (kg)	Packing (mm) Dimensions	Qty Pallet	Plumbing Requirements
Mini 1	1000180	11.2L	25.2L	140	520x360x540	140	2.8kW	30	450x450x800	1	3/4" BSP
Mini 2	1000200	11.8L	38.7L	215	520x360x540	140	4.3kW	30	450x450x800	1	3/4" BSP
Major 600 counter top	1000220	48L	54L	300	430x440x680	240	4.3kW	37	540x580x800	1	3/4" BSP
Major 900 under counter	1000260	57.5L	75.6L	420	460x470x700	200	8.4kW 3ph	37	540x580x800	1	3/4" BSP
Major 900 counter top	1000230	57.5L	75.6L	600	600x440x650	240	8.4kW 3ph	37	540x580x800	1	3/4" BSP
Major 1200 under counter	1000270	71.7L	108L	600	460x470x700	200	12kW 3ph	37	540x580x800	1	3/4" BSP
Under counter font	1000585				305x370x500	200		2			

Atmospheric water boilers

Manual Fill

Features

- Polished stainless steel
- Thermostatic control with automatic cut off
- Safety Non-drip lid
- Easy to clean and descale
- 10L, 20L & 27L capacity options
- Stainless steel quick boil element

Options

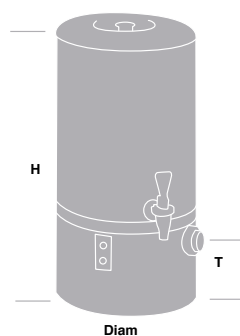

10L



27L



20L

Ideal for locations with no plumbed water and sites for temporary use, e.g. outdoor catering, occasional use & building sites.

Manual Fill	Order Code	Capacity	Diam (mm)	H(mm)	T(mm)	Power @ 230V	Weight (kg)	Packing (mm) Dimensions	Qty Pallet
Manual Fill 10L	10020	10L	230	495	170	3kW	5	290x290x500	48
Manual Fill 20L	10021	20L	290	570	170	3kW	7	340x340x580	36
Manual Fill 27L	10022	27L	400	545	170	3kW	9	440x440x550	16

Grinders

Best in class professional
and semi professional coffee grinders

Features

The Über Grinder allows brew by brew grinding with notable design features specifically aimed at optimizing each brew

Customised grinding burrs to ensure optimum extraction

Easy to clean and maintain

Easy to calibrate

Flat horizontal burrs for uniform, cool grinding to protect coffee



Über Grinder



Baratz Encore

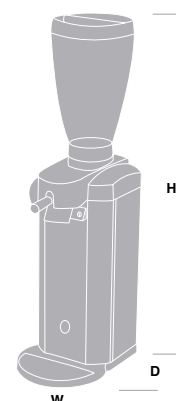

The ideal partner to Marco equipment when grind on demand is required for fresher brews.

Grinders	Order Code	Dimensions (DxWxHmm)	Weight (kg)	Packing (mm) Dimensions	Qty Pallet
Über Grinder	1000685	295x207x633	17.5	670x380x330	12
Baratz Encore	90099	152x127x356	4	180x200x370	120
Baratz Esatto	90075	311x133x26	1.65	155x100x370	200

Energy efficient pour and serve coffee machine

BRU

Features

- Professional grade brewer
- Manual and automatic fill options
- Improved sprayhead performance
- Ease of service and refurb
- Simple set up
- Robust construction
- Jug and flask variants

Options

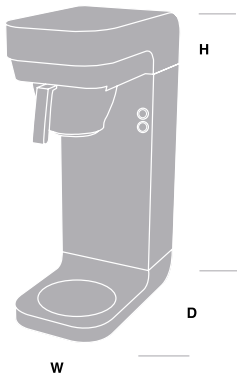

BRU F60M



BRU F45M

Ideal for high quality coffee for all catering locations – coffee shop, canteen, conference, offices and business locations.



	Order Code	Brew Capacity (L)	Dimensions (DxWxHmm)	Power @230V (kW)	Weight (kg)	Packaging (DxWxHmm)	Qty per Pallet	Plumbing Requirements
F45M Jug Manual Fill	1000900	1.8L	360x211x444	2.4	9kg	600x250x507	24	
F45A Jug Auto Fill	1000901	1.8L	360x211x444	2.4	9kg	600x250x507	24	¾" BSP
F60M Flask Manual Fill	1000902	2.2L	360x211x598	2.2	8kg	420x250x657	20	
F60A Flask Auto Fill	1000903	2.2L	360x211x598	2.2	8kg	420x250x657	20	¾" BSP
Airpot 2.2L	1700179				2kg	370x190x190	90	

Shuttle Brewers

Filter coffee machine /
insulated urn

Features

- Delivers coffee directly into portable urn
- Excellence in coffee
- Attractive design for prestigious locations
- Stainless steel construction
- Variable batch volumes
- Basket safety lock during brewing
- Easy to operate
- Pulse brew options
- Pre-infusion options
- Vacuum insulated Urn

Options



Filtro Shuttle



Mini Filtro Shuttle



Urn 6.0L

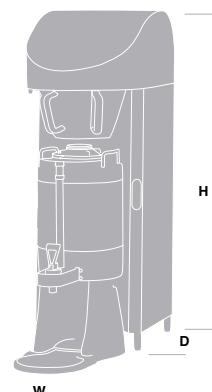

Ideal for medium to high volume coffee requirements,
e.g. hotels, restaurants and canteens.

Shuttle Brewers	Order Code	Full Brew	Cups Per Hour	Dimensions (DxWxHmm)	Power @ 230V	Weight (kg)	Packing (mm) Dimensions	Qty Pallet	Plumbing Requirements
Shuttle Brewer 5.6	1000650	5.5L	189	510x300x925	5.6kW	24.0	1060x620x440	3	3/4" BSP
Shuttle Brewer 2.8	1000651	5.5L	189	510x300x925	2.8kW	24.0	1060x620x440	3	3/4" BSP
Mini Shuttle Brewer 5.6	1000655	5.5L	189	510x300x690	5.6kW	17.5	620x440x800	6	3/4" BSP
Mini Shuttle Brewer 2.8	1000656	5.5L	189	510x300x690	2.8kW	17.5	620x440x800	6	3/4" BSP
Shuttle 6.0L	1700178			420x245x570		7.0	640x310x440	16	

Accessories

Filter Papers 8000150 (case of 500) **Urn Cleanser** 8000240

**Filter coffee machine /
bulk brew**

Qwikbrew

Features

- Boiler-brewer range
- Excellence in coffee
- Self-service options available
- Attractive design for prestigious locations
- Stainless steel construction
- Half and full brew feature
- Separate hot water and coffee taps
- Easy to operate
- Cost effective – maximum payback
- Push Button version available
- Alternative power options available on request
- Insulated urn an option upon request
- 3 volume brew options

Options

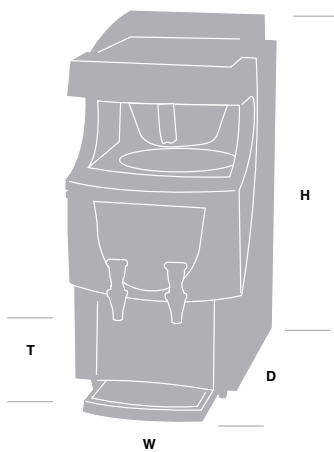

Push Button Qwikbrew



Qwikbrew

Ideal for high volume coffee requirements, e.g. hotels, restaurants and staff restaurants.



Qwikbrew	Order Code	Water		Coffee		Dimensions (DxWxHmm)	T(mm)	Power @230V	Weight (kg)	Packing (mm) Dimensions	Qty Pallet	Plumbing Requirements	
		Immediate Draw Off	Output Per Hour	Cups Per Hour	Full Brew								Cups Per Hour
Qwikbrew	1000379	5.7L	28.0L	156	5.5L	189	575x362x760	170	2.8kW	31	870x700x460	6	3/4" BSP
Qwikbrew 6	1000382	5.7L	56.0L	311	5.5L	189	575x362x760	170	5.6kW	31	870x700x460	6	3/4" BSP

Accessories

- Filter Papers** 8000150 (Case of 500)
- Urn Cleanser** 8000240

Qwikbrew Twin /Maxibrew Twin

Filter coffee machine /
bulk brew

Features

- Boiler-brewer range
- Excellence in coffee
- Stainless steel construction
- Half and full brew feature
- Separate hot water and coffee taps
- Self-service options available
- 2 coffee urns
- 2 full brews can run simultaneously
- Attractive design for prestigious locations
- Alternative power options available on request

Options



Maxibrew Twin



Qwikbrew Twin

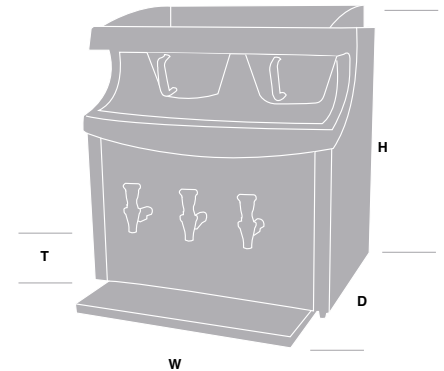

Ideal for very high volume coffee requirements,
e.g. hotels, banqueting and large canteens.



Qwikbrew	Order Code	Water			Coffee		Dimensions (DxWxH)mm	T(mm)	Power @230V	Weight (kg)	Packing (mm) Dimensions	Qty Pallet	Plumbing Requirements
		Immediate Draw Off	Output Per Hour	Cups Per Hour	Full Brew	Cups Per Hour							
Qwikbrew Twin	1000495	6.8L	56.0L	311	6L x 2	377	620x650x744	170	5.6kW	40	750x550x850	1	3/4" BSP
Maxibrew Twin	1000465	8.5L	84.0L	467	12L x 2	529	630x762x867	170	8.4kW 3ph	50	850x850x650	1	3/4" BSP
Maxibrew Twin front delivery push button	1000469	8.5L	84.0L	467	12L x 2	529	480x762x867	150	8.4kW 3ph	50	850x850x650	1	3/4" BSP

• Hot water & coffee taps can be used simultaneously; will affect maximum output of each. • Two full brews can be run simultaneously.

Bulk brew coffee machines for self-serve applications

Features

- Boiler brewers for high volume output
- Excellence in coffee
- Attractive design for prestigious locations
- Health and Safety conscious
- Stainless steel construction
- Half and full brew feature
- Easy to operate
- Cost effective

Options

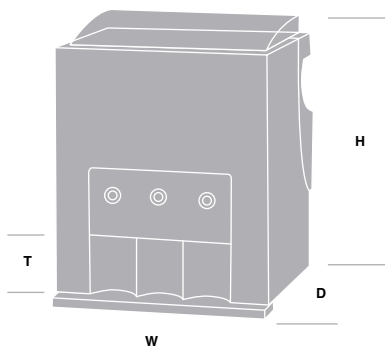

Qwikbrew Twin Rear Delivery

Qwikbrew Rear Delivery

Ideal for very high volume self serve coffee requirements, e.g. hotels, banqueting and large canteens.



Self Service Bulk Brew	Order Code	Water			Coffee		Dimensions (DxWxHmm)	T(mm)	Power @230V	Weight (kg)	Packing (mm) Dimensions	Qty Pallet	Plumbing Requirements
		Immediate Draw Off	Output Per Hour	Cups Per Hour	Full Brew	Cups Per Hour							
Qwikbrew rear delivery push button	1000384	5.7L	28.0L	156	5.5L	139	668x362x760	150	2.8kW	31	870x700x460	6	3/4" BSP
Qwikbrew twin rear delivery push button	1000492	6.8L	56.0L	311	5.5Lx2	377	695x650x744	150	5.6kW	40	750x550x850	1	3/4" BSP
Maxibrew twin rear delivery push button	1000481	8.5L	84.0L	467	11.5Lx2	529	735x762x855	150	8.4kW 3ph	50	850x850x650	1	3/4" BSP

- Hot water & coffee taps can be used simultaneously; will affect maximum output of each.
- Two full brews can be run simultaneously.
- Front delivery self-service options are available and detailed on Qwikbrew and Qwikbrew Twin specification pages.

Self Service Bulk Brew

Water Filter Systems

Marco is proud to partner with one of Europe's leading suppliers of water filtration systems.

Bestmax by water+more specialise in top technological solutions to optimise water products in the catering sector.

The technology used in the Bestmax range removes surplus and destructive limescale from tap water and transforms it into optimal water for coffee or tea.

1. Determine the Carbonate Hardness	2. By-pass Setting	3. Filter Capacity In Litres			
Carbonate Hardness in °KH*	Setting	S	M	L	XL
8	3	1025	3656	5150	7500
10	3	820	2925	4120	6000
12	2	620	2212	3115	4537
15	2	496	1769	2492	3630

Features

- 4-step filtration for constant water quality
- Including filtration of the bypass water
- Can be used horizontally and vertically
- Flexible – one connecting filter head for all product sizes
- Quick and easy filter change
- Low-cost operation
- Service-friendly due to short rinsing times

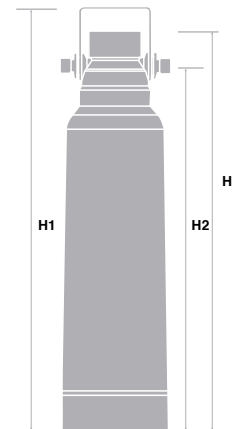

bestmax
best water technology

Bestmax

The partner of choice to maintain correct water quality for excellence in brewing.

Filters	Order Code	System	Replacement Cartridge	Packing (mm) Dimensions	(H1mm)	(H2mm)
Filter Besttaste X Kit	8000710	Carbon/Membrane	8000711	345	370	340
Filter Bestmax S Kit	8000720	Carbon/Resin	8000721	345	370	340
Filter Bestmax M Kit	8000730	Carbon/Resin	8000731	465	490	460
Filter Bestmax L Kit	8000740	Carbon/Resin	8000741	505	530	500
Filter Bestmax XL Kit	8000750	Carbon/Resin	8000751	505	530	500
Water testing kit	8000550					

1 Which Water Boiler?

To choose the appropriate machine for your application, follow the simple steps below. Alternatively call our customer service team on the number below. They will be happy to advise you.

Ireland +353 (0)1 295 2674 **UK** +44 (0)1933 666 488
Europe +31 (0)24 3782 883

- 2 Using the selection chart, pick the product which best meets your needs by answering these questions:

Question	Relevant Column
Do I want a plumbed-in unit?	Plumbed
Do I want 100°C water and steam?	Steam
Do I want to plug into an existing socket?	Single Phase 13amp
How many cups do I want at my busiest?	Immediate Draw-Off Cups
How many cups do I want on an ongoing basis?	Cups per Hour

Machine Selection Chart

Which coffee machine?

Using the selection chart below, pick the product which best meets your needs by answering the following questions:

Question	Relevant Column
Do I have mains water present?	Plumbed
Do I want to plug into an existing socket?	Single Phase 13amp
How many cups do I want at my busiest?	Full Brew Cups
Do I want water and coffee?	Hot Water

Water Boiler Selection Chart

	Page	Hot water	Plumbed	Steam	Single Phase 13amp Standard Plugtop	Single Phase 30A isolator	3 Phase Supply	Immediate draw off Litres	Immediate draw off cups	150 cups per hour	300 cups per hour	400 cups per hour	>600 cups per hour
Ecoboiler T5**	1	•	•		•			5	28	•			
Ecoboiler T10**	1	•	•		•			10	55	•			
Ecoboiler T20	1	•	•		•			20	110	•			
Ecoboiler T30	1	•	•			•		30	165		•		
Ecoboiler PB5 **	2	•	•		•			5	28	•			
Ecoboiler PB10 **	2	•	•		•			10	55	•			
Ecosmart PB10	3	•	•		•			10	55	•			
Ecoboiler WMT5 *	4	•	•			•		5	28	•			
Ecoboiler UC4	5	•	•		•			4	22	•			
Ecoboiler UC10	5	•	•		•	•		10	55	•			
Ecoboiler UC45	5	•	•			•	•	45	248		•		
Ecoboiler UC75	5	•	•		•			75	417				•
Über Boiler	6	•	•		•			6	34	•			
Mini 1	7	•	•	•	•			11.2	62	•			
Mini 2	7	•	•	•		•		11.8	66	•			
Major 900 Counter Top	7	•	•	•		•		57.5	319			•	
Major 900 Under Counter	7	•	•	•		•		57.5	319			•	
Major 1200 Under Counter	7	•	•	•		•		71.7	398				•

*Hard wired - no plug top **Manual fill option Note - Individual data sheets and Selection chart for older Marco products (Aquatius, Libra, etc) are available on the Marco website www.marcoeveragesystems.com

Coffee Machine Selection Chart

	Page	Coffee	Plumbed	Hot Water	Single Phase 13amp Standard Plugtop	Single Phase 30A isolator	3 Phase	Coffee Output					
								Full Brew Litres	Full Brew cups per hour	150 cups per hour	200 cups per hour	>300 cups per hour	>500 cups per hour
F45M Jug Manual Fill	10	•			•			1.8	85				
F60M Flask Manual Fill	10	•			•			2.2	85				
F45A Jug Auto Fill	10	•	•		•			1.8	85				
F60A Flask Auto Fill	10	•	•		•			2.2	85				
Shuttle Brewers 2.8kW	11	•	•		•	•		5.5	189		•		
Shuttle Brewers 5.6kW	11	•	•		•	•		5.5	189		•		
Qwikbrew	12	•	•	•	•			5.5	139	•			
Qwikbrew 6	12	•	•	•		•		5.5	189		•		
Qwikbrew Twin	13	•	•	•		•		5.5x2	377			•	
Maxibrew Twin	13	•	•	•		•		11.5x2	529				•

Definitions: 1. Immediate Draw Off: The volume of water in a full tank plus the water that enters the unit during dispense when connected to a normal mains supply.
2. Hourly Output: The minimum volume that can be delivered on an hourly basis.

NOTE: Self Service Bulk Brew data is identical to standard versions of Qwikbrew, Qwikbrew Twin and Maxibrew Twin.

Customer Care /Spares & Service

Marco Web

For the latest info and all product and technical downloads go to our website on www.marco beveragesystems.com

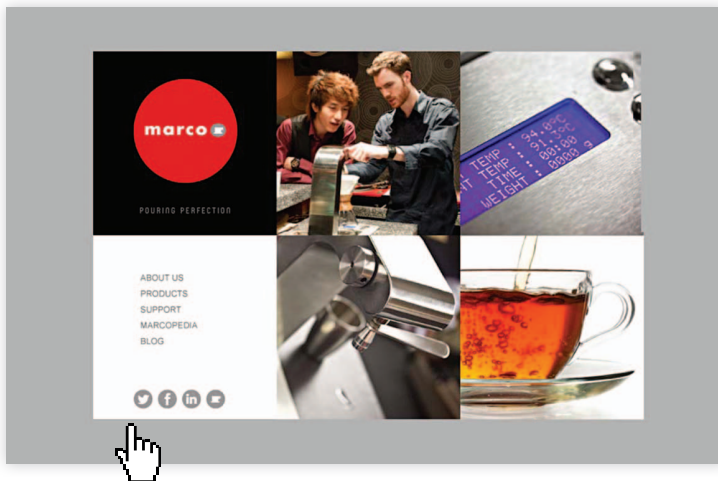

Customer Care

Our customer is the primary focus of our business. Our customer support centre exists to meet your requirements. Please contact us so that we can assist you to select the machine that best suits your needs. We shall be delighted to advise you on the best ways of brewing coffee and tea with expert advice on water treatment and machine care. You can select from a range of customer support options which we provide.

Ireland +353 (0)1 295 2674

UK +44 (0)1933 666 488

Europe +31 (0)24 3782 883



Technical Support

Contact our support centre for any advice you require, from selecting the appropriate machine for your needs to troubleshooting your technical enquiries.

ROI +353 1 295 2674 UK +44 (0)1933 666 488

Europe +31 (0)24 3782 883

Email

service@marcobeveragesystems.com

On-Line Technical Support

Our website provides direct access to product troubleshooting aids, operating manuals, spare parts lists and service manuals. Pdfs of all our product specification sheets and brochure information can be downloaded from the website. www.marcobeveragesystems.com

Marco's website also provides a range of information on current technical and legislative information.

On Site Service

We provide comprehensive on site service cover in Ireland and the UK, from installation to routine maintenance, using our engineers and a network of Marco trained service providers. All calls are managed using our real time information systems which allow us to keep you continually up to date with the process of your call.

Marco provides global technical support through our network of international partners, who are specialists trained and supported by our technical centre. You can be assured technical support will always be available for all your technical needs. Our partners provide a full range of services including initial installations, preventative maintenance contracts, troubleshooting, and upgrades as well as addressing all local sales.

Product Training

We provide a comprehensive training program for your engineers either at Marco or on your premises. We recommend you avail of this facility to ensure you achieve the best from your equipment and remain up to date on Marco product and technical developments. Detailed technical training is available on both our machines and on coffee brewing.

Spare Parts

Marco machines are designed for long life, to ensure you receive the maximum life cycle value. We carry all frequently used spare parts in stock at all times. We aim to ensure that no parts become obsolete.

Full spare parts listings and recommended stock holdings are available from our technical support centre or can be downloaded from our website. spares@marcobeveragesystems.com

Product History

Marco maintains a record of all machines manufactured by serial number. This allows us to provide you with a sales history of our sales to you and a service history of all service work we have carried out on your equipment.

Maintenance

We provide preventative maintenance contracts to help you maximise your investment in Marco machines. We recommend this as the best way in which to ensure you achieve the maximum benefit from your machines in the most cost effective manner. We welcome an opportunity to discuss your individual contract with you.